

Configuration Interaction and Organic Reactivity. I. Cycloadditions, Electrophilic Additions, Exchange Reactions, and Eliminations

Nicolaos D. Epiotis*¹

Contribution from the Department of Chemistry,
Princeton University, Princeton, New Jersey 08540. Received March 22, 1972

Abstract: The effect of configuration interaction on the stereoselectivity of cycloaddition reactions is examined by an orbital symmetry approach. It is shown that configuration interaction can reverse the stereoselectivity of 2 + 2 cycloadditions when the two cycloaddends have widely different polarities. On the other hand, configuration interaction cannot reverse the stereoselectivity of 4 + 2 cycloadditions. These results are in accord with conclusions previously obtained on the basis of a resonance formulation of the transition state of cycloaddition reactions. Experimental evidence relating to π - π , σ - π , and σ - σ cycloadditions is examined in the light of these findings.

The Woodward-Hoffmann rules² for predicting the stereoselectivity of concerted pericyclic reactions have stimulated an enormous amount of experimental work and have vividly illustrated the utility of theoretical predictions which are based on simple notions and do not require detailed computation. A number of other theoretical chemists, most notably Dewar,³ Zimmerman,^{4a} Fukui,^{4b} Salem,⁵ Trindle,⁶ and recently, Goddard⁷ have also discussed the stereochemistry of concerted pericyclic reactions in a variety of ways and their conclusions were in most instances in agreement with those of Woodward and Hoffmann. One common feature of all these one-electron treatments has been the choice of nonpolar model systems for the application of theory and the derivation of the rules.

We recently reported a systematic investigation of the stereoselectivity of thermal and photochemical π - π cycloadditions involving nonpolar and polar reactants.⁸ The reactants were classified into donor and acceptor cycloaddends and cycloadditions were shown to form a continuous spectrum ranging from nonpolar (AD) to polar (AX) cycloadditions. It was proposed that the transition state of a thermal cycloaddition can be represented by a resonance hybrid of a no-bond (NB) and a charge-transfer (CT) contributor.

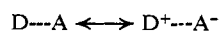

Of course, this is the type of description which is familiar to the organic chemist and, in a sense, corresponds to a limited configuration interaction (CI) treatment of the transition state of a pericyclic process. The relative stabilization of the s + a and s + s transition states for $2\pi + 2\pi$ and $4\pi + 2\pi$ cycloadditions were evaluated by assessing qualitatively the strength of the relevant orbital interactions in both s + a and s + s transition states. The qualitative assessment of the

strength of orbital interactions, carried out by perturbation theory,⁹ led to the following conclusions: (a) Nonpolar (AD) 2 + 2 cycloadditions will occur s + a, while polar (AX) 2 + 2 cycloadditions will occur s + s. (b) Both semipolar (AM) and polar (AX) 4 + 2 cycloadditions will occur s + s.

In view of these findings, we suggest that the non-stereospecificity of many 2 + 2 cycloadditions can be due not necessarily to the intermediacy of diradical or dipolar species but to competing concerted pathways. These nonstereospecific 2 + 2 cycloadditions will be typical AM-like 2 + 2 cycloadditions. The orbital symmetry approach of Woodward and Hoffmann² and Longuet-Higgins and Abrahamson² can be used as the theoretical framework in order to examine explicitly the effect of configuration interaction on stereoselectivity. Novel conclusions regarding the stereoselectivity of 2 + 2 and 4 + 2 cycloadditions are reached similar to ones we reported before.⁸ This analysis is extended here to σ - π and σ - σ cycloadditions. Finally, the applicability of the principle of least motion¹⁰ will be examined.

Non Least Motion Pathways and Correlation Diagrams. It is very important to define carefully the predictions which arise on the basis of an orbital symmetry correlation approach. The preferred mode of union of two cycloaddends is determined jointly by steric and electronic effects. Predictions derived from the construction of correlation diagrams correspond to electronic predictions. How is the electronic preference for a particular mode of union of cycloaddends modified by the steric factors influencing the reaction?⁸ It is instructive to consider a specific example. A $2\pi + 2\pi$ cycloaddition can proceed in an s + a non least motion manner or an s + s least motion manner, and it is apparent that the transition state involved in the non least motion process is much less favored on steric grounds than the one involved in the least motion process. A $2\pi + 2\pi$ cycloaddition will be s + a stereospecific if the s + a pathway is stabilized electronically to a much larger extent than the s + s pathway so that electronic factors dominate steric factors. On the

(1) Address correspondence to the Department of Chemistry, University of Washington, Seattle, Wash. 98105.

(2) R. B. Woodward and R. Hoffmann, "The Conservation of Orbital Symmetry," Academic Press, New York, N. Y., 1970; H. C. Longuet-Higgins and E. W. Abrahamson, *J. Amer. Chem. Soc.*, **87**, 2045 (1965).

(3) M. J. S. Dewar, *Angew. Chem., Int. Ed. Engl.*, **10**, 761 (1971).

(4) (a) H. E. Zimmerman, *Accounts Chem. Res.*, **4**, 272 (1971); (b) K. Fukui, *ibid.*, **4**, 57 (1971).

(5) L. Salem, *J. Amer. Chem. Soc.*, **90**, 543, 553 (1968).

(6) C. Trindle, *ibid.*, **92**, 3251, 3255 (1970).

(7) W. A. Goddard III, *ibid.*, **94**, 793 (1972).

(8) N. D. Epiotis, *ibid.*, **94**, 1924, 1935, 1941, 1946 (1972).

(9) M. J. S. Dewar, "The Molecular Orbital Theory of Organic Chemistry," McGraw-Hill, New York, N. Y., 1969.

(10) G. W. Wheland, "Advanced Organic Chemistry," 3rd ed, Wiley, New York, N. Y., 1960; J. Hine, *J. Org. Chem.*, **31**, 1236 (1966); *J. Amer. Chem. Soc.*, **88**, 5525 (1966).

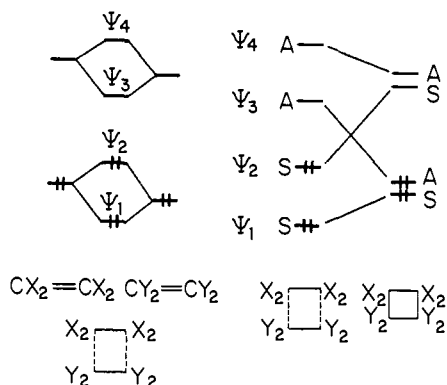

Figure 1. (a) The MO's of the transition state complex for a suprafacial AD $2\pi + 2\pi$ cycloaddition. (b) Correlation diagram for a suprafacial AD $2\pi + 2\pi$.

other hand, a $2\pi + 2\pi$ cycloaddition will be $s + s$ stereospecific if the $s + a$ pathway is stabilized electronically to only a slightly greater extent than the $s + s$ pathway so that steric factors dominate electronic factors. In general, one can argue that non least motion processes will be preferred over least motion processes whenever the electronic stabilization of the non least motion processes is much greater than the electronic stabilization of the least motion processes. On the other hand, least motion processes will be expected to dominate non least motion processes in either of the two following situations. (a) The least motion pathway is electronically stabilized to a greater extent than the non least motion pathway. (b) The least motion pathway is electronically favored less than the non least motion pathway but only to a small extent.

We shall now examine in detail the stereoselectivity of $2 + 2$ and $4 + 2$ cycloadditions by using correlation diagrams.

$2\pi + 2\pi$ Cycloadditions. The interaction diagram¹¹ (Figure 1) shows the MO's of the cycloaddends and the resultant MO's of the transition state complex of a typical $2_s + 2_s$ AD cycloaddition.¹² The energies of the MO's of representative cycloaddends have been determined by reference to ionization potential and ultraviolet spectroscopy data in the manner suggested before⁸ and also by Hückel and extended Hückel calculations.¹³ The energies of the MO's of the transition state complex have been obtained by means of the usual perturbation calculation. The correlation diagram (Figure 1) shows that the lowest state¹⁴ of the transition state complex correlates with a diexcited cyclobutane product and accordingly the reaction is not allowed. One would have to promote two electrons from ψ_2 to ψ_3 in order to render the reaction allowed in a $2_s + 2_s$

(11) For the theory underlying the construction of such diagrams see ref 8. Interaction diagrams can be qualitatively constructed by recognizing that the magnitude of the splitting of two energy levels is inversely proportional to their energy separation.

(12) A typical AD $2 + 2$ cycloaddition is the one of ethylene and tetramethylethylene.

(13) A. Streitwieser and J. I. Brauman, "Supplemental Tables of Molecular Orbital Calculations," Pergamon Press, Elmsford, N. Y., 1965; A. Streitwieser, "Molecular Orbital Theory for Organic Chemists," Wiley, New York, N. Y., 1961; R. Hoffmann, *J. Chem. Phys.*, **39**, 1397 (1963), and subsequent papers.

(14) The lowest state of the transition state complex is what one might have otherwise designated the ground state of the transition state complex.

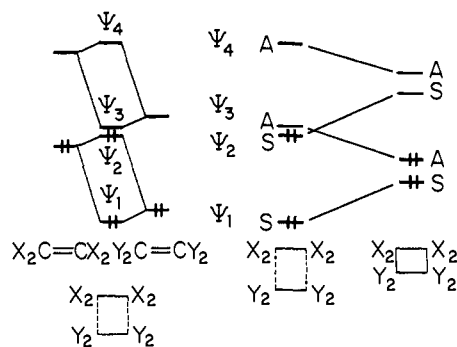

Figure 2. (a) The MO's of the transition state complex for a suprafacial AX $2\pi + 2\pi$ cycloaddition. (b) Correlation diagram for a suprafacial AX $2\pi + 2\pi$ cycloaddition.

manner.¹⁵ This would involve expenditure of considerable energy since the energy gap separating ψ_2 and ψ_3 is large and can be estimated to be of the order of 4–5 eV.¹⁶ The conclusion can be stated in an equivalent way. Specifically, in AD $2\pi + 2\pi$ cycloadditions configuration interaction is of minimal importance because the lowest state configuration of the transition state complex $\psi_1^2\psi_2^2$ and a diexcited configuration of the transition state complex $\psi_1^2\psi_3^2$ do not mix appreciably since their energies are substantially different. In other words, configuration interaction cannot effectively remove the forbiddenness of a $2_s + 2_s$ union of cycloaddends in an AD $2\pi + 2\pi$ cycloaddition. Such reactions will follow an alternative pathway involving $2_s + 2_a$ union of the cycloaddends since the lowest state transition state complex correlates with a ground state cyclobutane product and the reaction is allowed.^{2,17} The difference in electronic stabilization of the $2_s + 2_a$ and $2_s + 2_s$ pathways can be appreciable. In summary, one can state that in nonpolar AD $2\pi + 2\pi$ cycloadditions configuration interaction fails to remove the forbiddenness of the least motion pathway and the reaction follows a non least motion pathway. The additional possibility of a two-step reaction is regarded as obvious and is not discussed explicitly here or subsequently.

The interaction diagram of Figure 2 shows the MO's of the cycloaddends and the resultant MO's of the transition state complex of a typical $2_s + 2_s$ AX cycloaddition. An AX cycloaddition involves an electron acceptor olefin and an electron donor olefin. In general, electron acceptor olefins are characterized by a low-lying LUMO and electron donor olefins by a high-lying HOMO. The energies of the MO's of the cycloaddends and the transition state complex for representative systems have been obtained in the same way as in the previous case. The correlation diagram of Figure 2 shows again that the lowest state of the transition state complex correlates with a diexcited cyclobutane product and accordingly the reaction is formally not allowed. One would have to promote two electrons from ψ_2 to ψ_3 in order to render the reaction allowed in a $2_s + 2_s$ manner. Unlike the previous case, this will now involve only a small energy expenditure since the energy gap separating ψ_2 and ψ_3 is small. This result can also be stated in an equivalent way. Specific-

(15) The MO's of all transition state complexes are denoted by ψ_n .

(16) See also ref 2.

(17) M. Caserio, *J. Chem. Educ.*, **48**, 762 (1971).

cally, in AX $2_\pi + 2_\pi$ cycloadditions configuration interaction is of extreme importance because the lowest state configuration of the transition state complex $\psi_1^2\psi_2^2$ strongly mixes with a diexcited configuration of the transition state complex $\psi_1^2\psi_3^2$ since the energies of the two configurations are comparable. In other words, configuration interaction effectively removes the forbiddenness of a $2_s + 2_s$ union of cycloaddends in an AX $2_\pi + 2_\pi$ cycloaddition.¹⁸ The reaction is still allowed to proceed in a $2_s + 2_a$ manner since the transition state complex still correlates with a ground state cyclobutane product. However, AX $2_\pi + 2_\pi$ cycloadditions may well occur in a $2_s + 2_s$ manner since the $2_s + 2_a$ pathway is favored electronically but is strongly disfavored sterically relative to the $2_s + 2_s$ pathway. In summary, in polar AX $2_\pi + 2_\pi$ cycloadditions configuration interaction can effectively remove the forbiddenness of the least motion pathway and the reaction could follow the $2_s + 2_s$ approach. Thus, $2_\pi + 2_\pi$ cycloadditions will form a reactivity spectrum ranging from nonpolar $2_s + 2_a$ to polar $2_s + 2_s$ cycloadditions. These conclusions are identical with those reached on the basis of perturbation analysis.⁸ The Dewar approach to pericyclic reactions is also admirably suited to a discussion of the stereochemistry of $2_\pi + 2_\pi$ cycloadditions. According to this approach, the transition state of a nonpolar $2_\pi + 2_\pi$ cycloaddition is isoconjugate to antiaromatic cyclobutadiene when $2_s + 2_s$ union of the cycloaddends is involved.



Similarly, the transition state of a polar $2_\pi + 2_\pi$ cycloaddition is isoconjugate to antiaromatic cyclobutadiene when $2_s + 2_s$ union of the cycloaddends is involved.

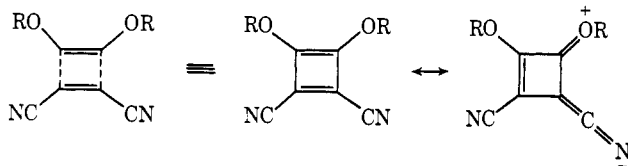

In the nonpolar case resonance does not reduce the antiaromaticity of cyclobutadiene, while in the polar case resonance can destroy the antiaromaticity of cyclobutadiene and one is led to conclusions similar to the ones stated before. At this point, it should be noted that the head-to-tail dimerization of olefins of the type shown below can lead to $2_s + 2_s$ cycloaddition since resonance can destroy the antiaromaticity of the transition state of a $2_s + 2_s$ cycloaddition.^{19b} Ob-

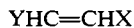

X = electron releasing group;
Y = electron withdrawing group

viously, this is a special type of $2 + 2$ AA cycloaddition and will be discussed by us elsewhere.

Experimental cases of $2_\pi + 2_\pi$ cycloadditions drawn from the literature and strongly indicating that our qualitative predictions are valid have been cited before.^{8, 20}

(18) A typical AX $2 + 2$ cycloaddition will be the one of tetracyanoethylene and dimethoxyethylene.

(19) (a) For estimates see ref 8. (b) In this connection see R. Gompper and G. Seybold, *Angew. Chem., Int. Ed. Engl.*, **7**, 824 (1968); R. Gompper, *ibid.*, **8**, 312 (1969).

(20) New examples continue to find their way to print. For an important class of AX $2 + 2$ cycloadditions, see C. S. Foote, *Pure Appl. Chem.*, **27**, 635 (1971).

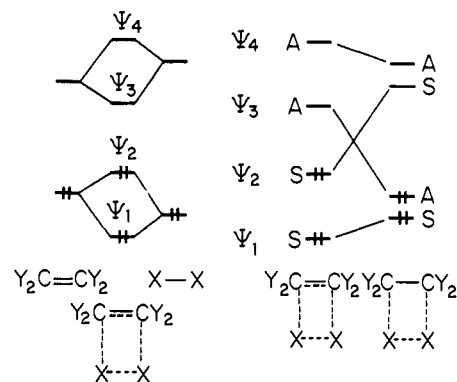
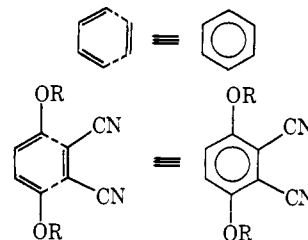

Figure 3. (a) The MO's of the transition state complex for a suprafacial AD $2_\pi + 2_\sigma$ cycloaddition. (b) Correlation diagram for a suprafacial AD $2_\pi + 2_\sigma$ cycloaddition.

$4_\pi + 2_\pi$ Cycloadditions. Both semipolar (AM) and polar (AX) $4_\pi + 2_\pi$ cycloadditions are predicted to occur in a $4_s + 2_s$ manner on the basis of orbital symmetry considerations. In such cases the least motion pathway will always be preferred over the non least motion pathway. The well-known stereospecificity of the Diels-Alder reaction is in good accord with these predictions.^{21a}

The Dewar model leads to similar predictions. The $4_s + 2_s$ transition state of the cycloaddition of butadiene and ethylene is isoconjugate to benzene and typical of an AM $4_\pi + 2_\pi$ cycloaddition. On the other hand, the $4_s + 2_s$ transition state of the cycloaddition of an electron rich butadiene and an electron poor ethylene is isoconjugate to a substituted benzene and typical of an AX $4_\pi + 2_\pi$ cycloaddition. In both cases the reaction proceeds in a $4_s + 2_s$ manner because the transition state is aromatic and the aromaticity is not destroyed by substituents.



The ideas expressed in this section are also applicable to structural problems. Recently, Goldstein and Hoffmann^{21b} provided a topological definition of aromaticity. They considered unsubstituted molecules as models for the derivation of simple rules regarding molecular stability. According to our analysis, it is expected that in many instances the "antiaromaticity" of a molecule as predicted by the approach of Goldstein and Hoffmann will be eliminated by appropriate substitution. It would be interesting to develop an experimental stability index so that the effect of substituents on the "aromaticity" or "antiaromaticity" of molecules can be conveniently explored.

$2_\pi + 2_\sigma$ Cycloadditions. The interaction diagram of Figure 3 shows the MO's of the cycloaddends and the resultant MO's of the transition state complex of a

(21) (a) R. Huisgen, R. Grashey, and J. Sauer, in "The Chemistry of Alkenes," S. Patai, Ed., Wiley, New York, N. Y., 1964; (b) M. J. Goldstein and R. Hoffmann, *J. Amer. Chem. Soc.*, **93**, 6193 (1971).

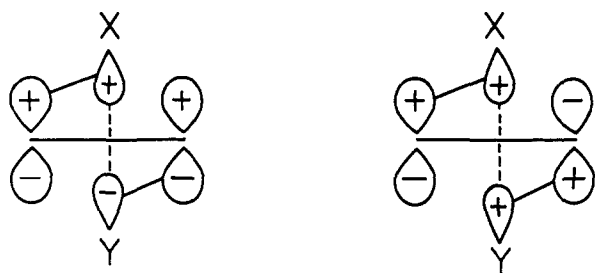

Figure 4. Crucial orbital interactions in the concerted trans addition of X-Y to an olefin. The bond of X-Y is assumed to be stretched.

typical cis AD cycloaddition. The energies of the MO's of representative cycloaddends have been determined by reference to ionization potential and ultraviolet spectroscopy data in the manner suggested before and also by Hückel and extended Hückel calculations. The energies of the MO's of the transition state complex have been obtained *via* the usual perturbation treatment. The related correlation diagram shows that the lowest state transition state complex correlates with a diexcited addition product and accordingly the reaction is not allowed. One would have to promote two electrons from ψ_2 to ψ_3 in order to render the reaction allowed in a cis manner. This will involve expenditure of considerable energy since the energy gap separating ψ_2 and ψ_3 is large. The result can be stated in another equivalent way. Specifically, in AD $2_\pi + 2_\sigma$ cycloadditions configuration interaction is of minimal importance because the lowest state configuration of the transition state complex $\psi_1^2\psi_2^2$ and a diexcited configuration of the transition state complex $\psi_1^2\psi_3^2$ do not appreciably mix since their energies are substantially different. In other words, configuration interaction cannot effectively remove the forbiddenness of a cis union of the cycloaddends in a AD $2_\pi + 2_\sigma$ cycloaddition. An analysis based on simple perturbation theory indicates that AD $2_\pi + 2_\sigma$ cycloadditions can proceed in a trans manner since the trans addition pathway is electronically stabilized by the main orbital interactions of the two cycloaddends.²² The principal orbital interactions stabilizing concerted trans addition are shown in Figure 4. It is expected that AD $2_\pi + 2_\sigma$ cycloadditions will occur in a trans manner since the trans addition pathway is electronically favored to a large extent over the cis addition pathway. In summary, one can state that in AD $2_\pi + 2_\sigma$ cycloadditions configuration interaction fails to remove the forbiddenness of the least motion pathway and the reaction follows a non least motion pathway.

The interaction diagram of Figure 5 shows the MO's of the cycloaddends and the resultant MO's of the transition state complex of a typical cis AX cycloaddition. The energies of the MO's of the cycloaddends and the transition state complex for representative systems have been obtained in the same way as in the previous case. The related correlation diagram shows again that the lowest state transition state complex correlates with a diexcited addition product and accordingly the reaction is formally not allowed. One would have to promote two electrons from ψ_2 to ψ_3 in

(22) See also K. Fukui and H. Fujimoto, *Bull. Chem. Soc. Jap.*, **39**, 2116 (1966).

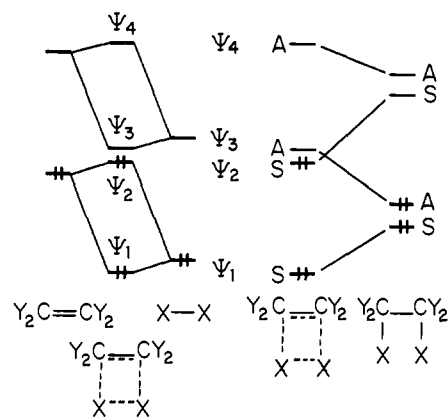
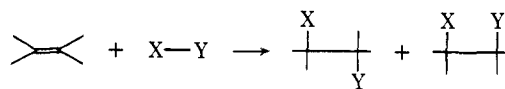

Figure 5. (a) The MO's of the transition state complex for a suprafacial AX $2_\pi + 2_\sigma$ cycloaddition. (b) Correlation diagram for a suprafacial AX $2_\pi + 2_\sigma$ cycloaddition.

order to render the reaction allowed in a cis manner. Unlike the previous case, this will now involve only a small energy since the energy gap separating ψ_2 and ψ_3 is small. The result can be stated in another equivalent way. Specifically, in AX $2_\pi + 2_\sigma$ cycloadditions configuration interaction is very prominent because the lowest state configuration of the transition state complex can strongly mix with a diexcited configuration of the transition state complex since the energies of the two configurations are comparable. In other words, configuration interaction effectively removes the forbiddenness of cis addition in AX $2_\pi + 2_\sigma$ cycloadditions. On the other hand, the reaction can still proceed in a trans manner since the trans addition pathway is still stabilized. However, one can reasonably expect that AX $2_\pi + 2_\sigma$ cycloadditions will occur in a cis manner since the trans addition pathway is favored electronically over the cis pathway, but strongly disfavored sterically relative to it. In a concerted trans addition both non-bonded repulsions and poor orbital overlap at the transition state make such a reaction very unfavorable relative to a concerted cis addition. To summarize, configuration interaction in AX $2_\pi + 2_\sigma$ cycloadditions effectively removes the forbiddenness of the least motion pathway and the reaction follows this pathway.

In accordance with the above considerations, it is expected that $2_\pi + 2_\sigma$ cycloadditions will form a reactivity spectrum ranging from trans to cis cycloadditions as the electron donating ability of the olefin varies from moderate to very strong and the electron accepting ability of the saturated molecule varies similarly from moderate to very strong.²³

Addition reactions of X-Y to olefins in solution have been extensively investigated in the last 2 decades.²⁴ Electrophilic additions to olefins generally have been discussed in terms of two-step mechanisms involving



electrophilic attack followed by nucleophilic attack. The following mechanisms can be envisioned.

(23) These concerted reactions are, of course, bimolecular in nature.

(24) For excellent reviews see P. B. D. de la Mare and R. Bolton, "Electrophilic Additions to Unsaturated Systems," Elsevier, New York, N. Y., 1966; R. C. Fahey, *Top. Stereochem.*, **3**, 237 (1968).

Table I. Stereochemistry of Electrophilic Additions to Olefins

Olefin	Addend		
	F ₂ -CCl ₃ F	Cl ₂ -CCl ₄	Br ₂ -CCl ₄
<i>trans</i> -1-Phenylpropene	79% <i>cis</i> -31% <i>trans</i> ^a	46% <i>cis</i> -38% <i>trans</i> ^c	Mostly <i>trans</i> ^e
<i>cis</i> -1-Phenylpropene	78% <i>cis</i> -22% <i>cis</i> ^a	62% <i>cis</i> -29% <i>trans</i> ^c	Mostly <i>trans</i> ^e
Indene	100% <i>cis</i> ^b	Mostly <i>cis</i> ^d	

^a R. F. Meritt, *J. Amer. Chem. Soc.*, **89**, 609 (1967). ^b R. F. Meritt and F. A. Johnson, *J. Org. Chem.*, **31**, 1859 (1966). ^c R. C. Fahey and C. Schubert, *J. Amer. Chem. Soc.*, **87**, 5172 (1965). ^d L. T. Stach, Ph.D. Thesis, Northwestern University, Evanston, Ill., 1963. ^e R. C. Fahey and H. J. Schneider, *J. Amer. Chem. Soc.*, **90**, 4429 (1968).

(a) Cis molecular addition

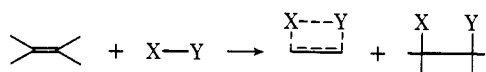

(b) Bimolecular stepwise addition involving a cationic intermediate. This can be a symmetric or nonsymmetric "onium" ion.

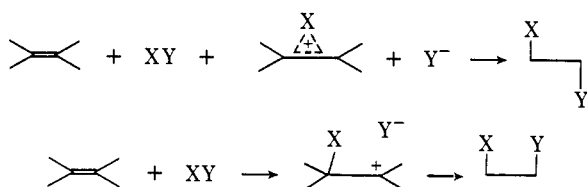

(c) Termolecular stepwise addition involving a cationic intermediate. Again, this can be a symmetric or nonsymmetric "onium" ion.

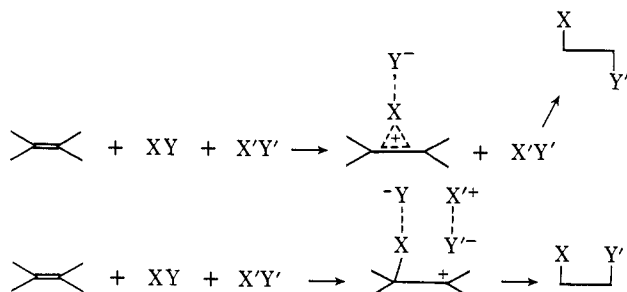

While many electrophilic additions to olefins can occur in a stepwise manner according to one or more than one of the mechanisms outlined above, it is interesting to inquire if concerted *trans* and *cis* additions to olefins as predicted by our theory are also compatible with the available experimental data. We shall assume that electrophilic additions to olefins can be regarded as $2_\pi + 2_\sigma$ cycloadditions and examine representative experimental results. According to our theory, the stereochemistry of concerted additions changes from predominantly *trans* to predominantly *cis* as one increases the nucleophilicity of the olefin or the electrophilicity of the addend X-Y. This happens because in altering the electronic properties of the cycloaddends in the manner indicated above one proceeds from an AD to an AX type of $2_\pi + 2_\sigma$ cycloaddition and an AD $2_\pi + 2_\sigma$ cycloaddition is predicted to occur *trans* while an AX $2_\pi + 2_\sigma$ cycloaddition is predicted to occur *cis*. The spectrum of $2_\pi + 2_\sigma$ cycloadditions, where the olefin acts generally as the donor and the saturated molecule as the acceptor, is schematically shown below. One can shift to the left or the right of the spectrum by systematically changing the electronic

electron acceptor olefin	ethylene	electron donor olefin
+	+	+
X-Y	X-Y	X-Y
AD	AM	AX

properties of the olefin and the saturated addend. Increasing nucleophilicity of the olefin, reflected in increasing energy of the highest occupied π MO, shifts the reaction to the right of the spectrum. Similarly, increasing electrophilicity of the addend, reflected in decreasing energy of the lowest unoccupied σ MO, also shifts the reaction to the right of the spectrum. There are several experimental observations which are qualitatively in accord with our scheme.

While additions of HCl, HBr, and Cl₂ to simple olefins occur in a preferred *trans* manner, additions of the same molecules to arenes and good electron donor olefins occur in a preferred *cis* manner.²⁴ Representative examples are shown below.²⁵ Furthermore, addi-

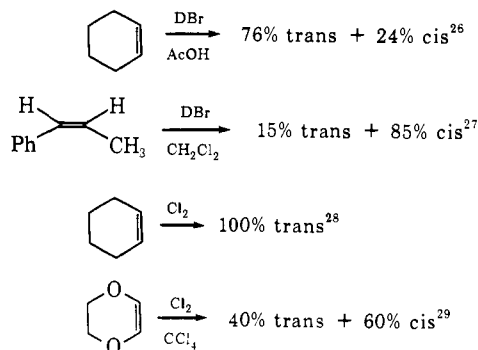

tion of the isomeric 1-phenylpropenes, indene, and other arenes to the diatomics F₂, Cl₂, and Br₂ shows increased *cis* stereoselectivity as one goes from Br₂ to F₂ and this is shown in Table I. On the other hand, there are strong indications that "onium" ion stability increases in the order Br > Cl > F.³⁰ It is very probable

(25) For additional examples see ref 24, and for a discussion of the mechanism of these reactions in the light of the principle of the conservation of orbital symmetry, see S. I. Miller, *Advan. Phys. Org. Chem.*, **6**, 185 (1968).

(26) I. V. Smirnov-Zamkov and G. A. Piskovitina, *Ukr. Khim. Zh.*, **28**, 531 (1962).

(27) M. J. S. Dewar and R. C. Fahey, *J. Amer. Chem. Soc.*, **85**, 3645 (1963).

(28) M. L. Poutsma, *ibid.*, **87**, 2161 (1965).

(29) R. K. Summerbell and H. E. Lunk, *ibid.*, **79**, 4802 (1957).

(30) (a) R. D. Bach and H. F. Henneke, *ibid.*, **92**, 5589 (1970). (b) The well-documented *cis* electrophilic additions to norbornene are consistent with this viewpoint and they probably occur despite the fact that norbornene is not a good electron donor because the alternative pathways are not very favorable. For an excellent discussion of this topic see T. G. Traylor, *Accounts Chem. Res.*, **2**, 152 (1969).

that cis concerted addition dominates the nonconcerted pathway in the case of F_2 addition while the reverse occurs in the case of Br_2 addition. The nonconcerted pathway would presumably involve "onium" ion intermediates. Systematic studies involving variation of the olefin partner under identical conditions might be needed to conclusively test our predictions.

The discussion of electrophilic additions to olefins as concerted $2_\pi + 2_\sigma$ cycloadditions allows conclusions to be drawn which seem to be qualitatively in agreement with experimental evidence. Naturally, this does not prove that electrophilic additions to olefins are all concerted processes. Indeed, the results stated above are also explicable by stepwise mechanisms. We believe that the non least motion trans addition to olefins can be a higher energy process than the alternative stepwise process involving a cationic intermediate and that simple olefins are most probably undergoing addition by a stepwise mechanism. The situation is analogous to that encountered in nonpolar $2_\pi + 2_\pi$ cycloadditions where again the non least motion pathway involving $2_s + 2_a$ cycloaddition might, in cases, be of higher energy than the alternative pathway involving biradical intermediates. Solvent effects seem to be consistent with this viewpoint since it is found that trans electrophilic addition to olefins shows a marked response to solvent variation. Concerted trans addition would not have been expected to be significantly affected by solvent changes. On the other hand, we believe that cis addition to olefins is probably a concerted process which is favored over a two-step process involving a cationic intermediate and which is expected to materialize when the olefin has a low ionization potential and the addend a low lying lowest unoccupied σ^* MO.^{30b} The transition state of such concerted cis additions may very well involve different degree of bond making at the two union sites. In such cases one may expect that solvent effects will probably manifest themselves since configuration interaction effectively redistributes electrons between the two cycloaddends and the transition state will probably have appreciable polarity.

Another general type of reaction which can formally be classified as a $2_\pi + 2_\sigma$ cycloaddition is the addition of olefins to strained carbocyclic σ bonds.³¹

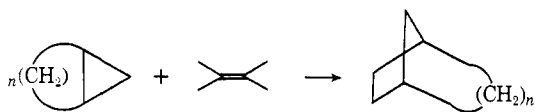

Gassman³¹ has proposed that these reactions occur in a stepwise manner and involve diradical intermediates.

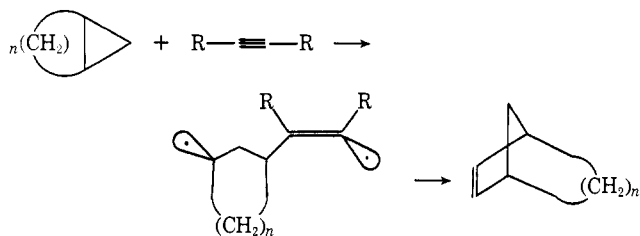

Again, it is interesting to examine if the experimental evidence is consistent with a concerted mechanism of

(31) P. G. Gassman, *Accounts Chem. Res.* 4, 128 (1971); A. Cairncross and E. P. Blanchard, Jr., *J. Amer. Chem. Soc.*, 88, 496 (1966).

addition. We first have to recognize that nonbonded interactions and poor orbital overlap at the transition state preclude a concerted trans addition of the strained bond to the olefin. The strained σ bond will constitute the donor partner in its cycloadditions with olefins of varying electronic nature. According to our theory, it is predicted that cis concerted addition will become increasingly favorable as the ionization potential of the olefins increases since configuration interaction becomes increasingly important under these circumstances and removes the forbiddenness of cis addition. As the electrophilicity of the olefin partner increases, concerted cis addition should become increasingly prominent and the rate and cis stereoselectivity of the reaction will also increase. Indeed, it was found that increasing electrophilicity of the olefin partner led to enhanced reaction rates. The following order of reactivity was established for various substituted acetylenes and ethylenes.³¹

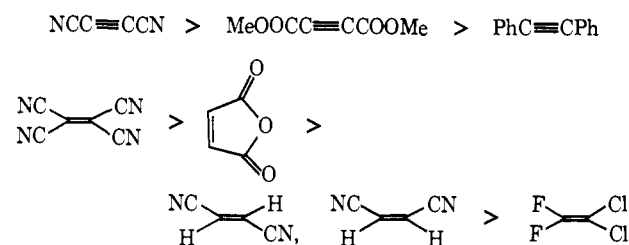

It was also found that the reaction of bicyclo[2.1.0]pentane with either fumaronitrile or maleonitrile is highly stereoselective³¹ (Scheme I).

Scheme I

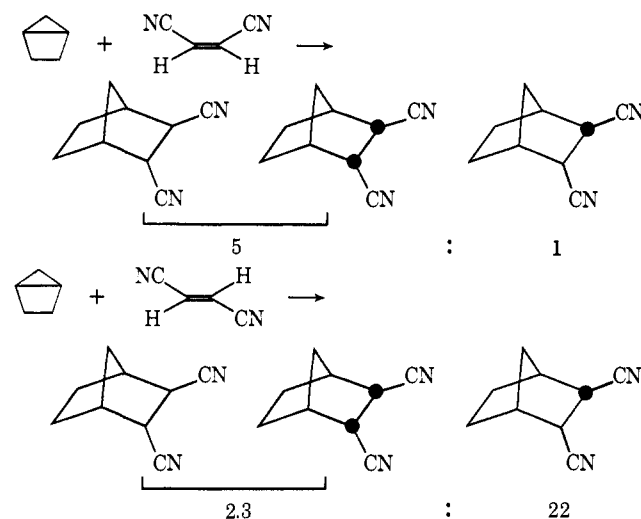

These results are not necessarily the results that one would normally expect from a reaction proceeding *entirely* through biradical intermediates. Specifically, simple perturbation theory tells us that phenyl groups can be very efficient stabilizers of a radical site. This arises because of the strong interaction of one of the degenerate doubly occupied MO's of the phenyl group with the singly occupied carbon p-orbital and Figure 6 illustrates this situation. The inertness of diphenylacetylene cannot be explained in terms of a diradical mechanism. Furthermore, the stereoselectivity of the reaction of bicyclo[2.1.0]pentane with both fumaronitrile and maleonitrile is indicative of a concerted process although does not disprove the biradical hypothesis.

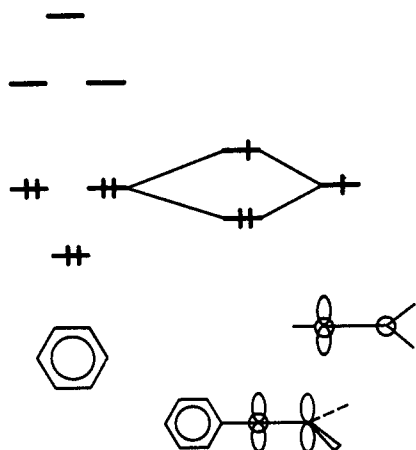
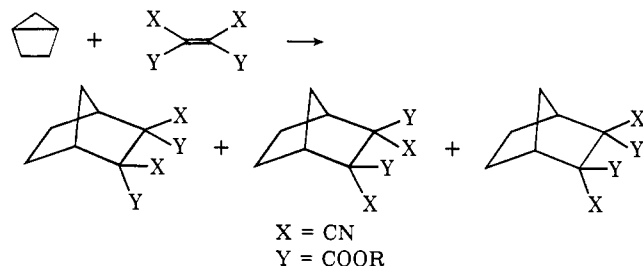

Figure 6. Stabilization of a vinyl radical center by phenyl.

A simple reaction could distinguish between the above possibilities (Scheme II). If a biradical mechanism is

Scheme II



predominant, then this reaction should be less stereoselective than the corresponding reaction of maleonitrile since the biradical intermediate will presumably be more stable and have a longer lifetime so that it will undergo more rotation prior to closure. If our arguments are applicable to this type of reaction, then greater cis stereoselectivity will be expected for this reaction rather than the corresponding addition of maleonitrile.

The reaction of bicyclo[2.1.0]pentane with fumaronitrile and maleonitrile leads to the formation of products which, in principle, can be rationalized by stepwise mechanisms involving biradical intermediates. While these products may indeed arise from such intermediates it is possible that the transition states for the concerted and stepwise processes lie close in energy.³² Clearly, more work should provide a better understanding of these reactions.

$4_\pi + 2_\sigma$ Cycloadditions. All $4_\pi + 2_\sigma$ cycloadditions are expected to occur in a cis manner on the basis of orbital symmetry considerations. In such cases the least motion pathway will always be preferred over the non least motion pathway. It is interesting that such reactions have not been extensively studied. The 1,4 addition of HBr to cyclohexadiene was found to be cis, but this result is also consistent with a stepwise mechanism involving a cationic intermediate.³³ Further studies of electrophilic additions to dienes might differentiate between the two-step and the concerted mechanisms.

(32) This can possibly account for the temperature and solvent effects observed by Gassman.

(33) G. S. Hammond and J. Warkentin, *J. Amer. Chem. Soc.*, **83**, 2554 (1961).

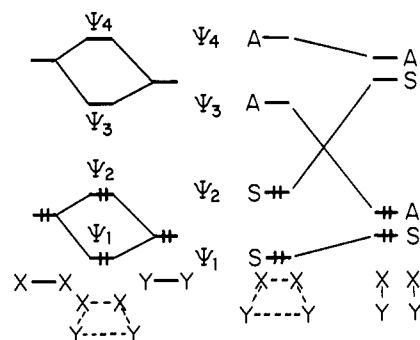

Figure 7. (a) The MO's of the transition state complex for a suprafacial AD $2_\sigma + 2_\sigma$ cycloaddition. (b) Correlation diagram for a suprafacial AD $2_\sigma + 2_\sigma$ cycloaddition.

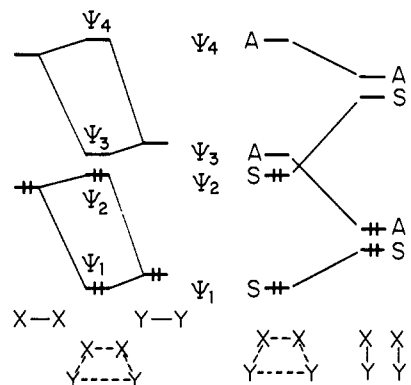
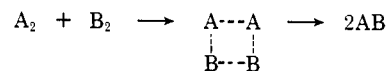

Figure 8. (a) The MO's of the transition state complex for a suprafacial AX $2_\sigma + 2_\sigma$ cycloaddition. (b) Correlation diagram for a suprafacial AX $2_\sigma + 2_\sigma$ cycloaddition.

$2_\sigma + 2_\sigma$ Cycloadditions. This situation is formally analogous to the situation encountered in $2_\pi + 2_\pi$ cycloadditions. The appropriate interaction diagrams for an AD and an AX cycloaddition are shown in Figure 7 and Figure 8, respectively. In both cases it is assumed that the reaction involves a four-center trapezoidal transition state complex although other geometries are possible. By going through the same arguments as in the case of $2_\pi + 2_\pi$ cycloadditions, one can conclude that in the AD case configuration interaction cannot effectively remove the forbiddenness of the reaction, while in the AX case configuration interaction can lift the forbiddenness of the reaction. These conclusions are valid for any four-center arrangement of the transition state complex.³⁴

The exchange reaction shown below can be regarded as a $2_\sigma + 2_\sigma$ cycloaddition proceeding *via* a trapezoidal, tetrahedral, or square complex.



According to our treatment, it is expected that as the electron donating and accepting ability of A_2 becomes progressively smaller or greater than the electron accepting and donating ability of B_2 configuration interaction will progressively lower the barrier to a concerted four-center reaction. This prediction is beautifully demonstrated by the valence bond calculations of Raff and Porter who studied the following reactions.³⁵

(34) R. A. Jackson, *J. Chem. Soc. B*, 58 (1970).

(35) L. M. Raff and R. N. Porter, *J. Chem. Phys.*, **51**, 4701 (1969).

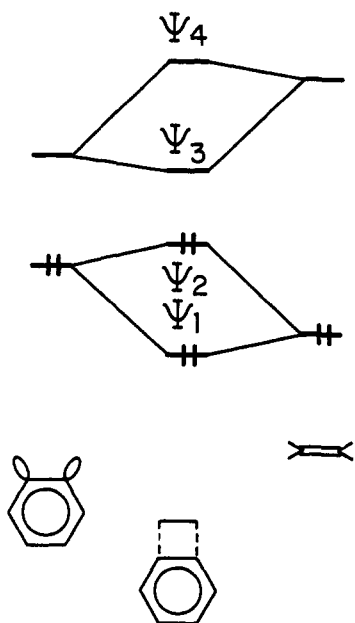
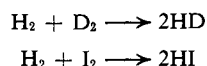

Figure 9. The MO's of the transition state complex for a suprafacial union of benzyne and ethylene.



It was found that configuration interaction is more significant in the hydrogen-iodine reaction and the barrier of this reaction was calculated to be lower than the barrier to the hydrogen dimerization reaction. More calculations of this type with a graded series of diatomics are desirable.

Cycloreversions. In the previous sections we considered various representative types of cycloadditions. It is interesting to see if experimental results pertaining to reverse cycloadditions are consistent with our conclusions. Since this is not intended to be an exhaustive survey of the literature, we have selected only representative examples.

An interesting cycloreversion has been studied by Paquette, *et al.*³⁶ These workers studied the thermal fragmentation of [4.4.2]propella-2,4-dienes bearing different substituents.

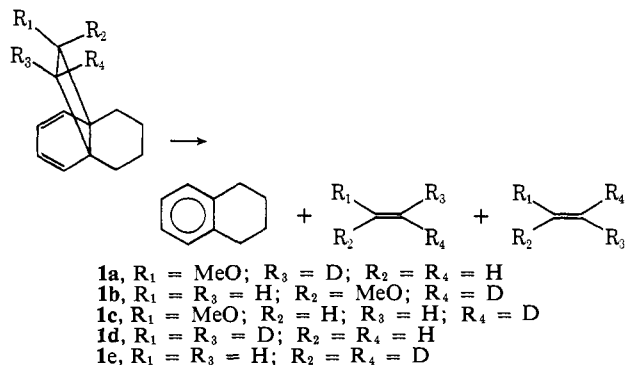

Because of the rigidity of the cyclobutane ring, it was expected that this $2_\pi + 2_\pi$ cycloreversion would involve diradical intermediates. According to our theory it is expected that increased substitution of the two carbon bridge by electron-donating substituents

(36) L. A. Paquette and G. L. Thompson, *J. Amer. Chem. Soc.*, **93**, 4920 (1971).

will lead to increased preference for concerted $2_s + 2_s$ elimination. This prediction was borne out by the results of this study as the data of Table II indicate.

Table II. Effect of Substituents on the Stereochemistry of Cycloreversion of 1

Substrate	Temp, °C	% stereochemical retention in olefin product
1a	245	95
1b	245	80
1c	314	>90
1d + 1e	310	66

Methyl vinyl ether (ionization potential = 8.93 eV)³⁷ is a much better donor than ethylene (ionization potential = 10.5 eV),³⁷ and its corresponding cycloreversion is expected to involve a greater $2_s + 2_s$ concerted reaction component.

Gas-phase elimination reactions constitute typical $2_\pi + 2_\sigma$ cycloreversion reversions.

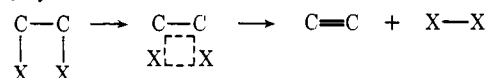

These reactions have been extensively studied and formulated as four-center reactions involving an ion-pair like transition state.³⁸ According to our theory, configuration interaction lowers the barrier to cis concerted $2_\pi + 2_\sigma$ cycloreversions involving a good electron donor olefin and a good σ acceptor molecule. Furthermore, the polarity of the transition state of such concerted $2_\pi + 2_\sigma$ cycloreversions is expected to be appreciable since configuration interaction leads to a redistribution of electrons between the two cycloreversion partners. Variants of the polar transition state anticipated on the basis of our theory have already been proposed on the basis of other considerations by Maccoll and Benson.³⁸

Cycloadditions of Reactive Species. In the last few years there has been great interest in the reactions of highly reactive intermediates like benzyne³⁹ and the reactions of highly unstable molecules like cyclobutadiene.⁴⁰ The extreme reactivity of these species is in a sense due to the existence of a high energy HOMO and a low energy LUMO. These MO properties lead to some interesting consequences in the cycloaddition of these species to unsaturated molecules.

Figure 9 shows the interaction diagram for the $2_\pi + 2_\pi$ cycloaddition of benzyne and ethylene proceeding in a $2_s + 2_s$ manner. The relative energies of the MO's of the cycloaddends have been obtained from already existing calculations⁴¹ and the relative energies of the MO's of the transition state complex from perturbation calculations. A correlation diagram can be constructed and it shows that the $2_s + 2_s$ reaction is forbidden. However, configuration interaction which

(37) K. Watanabe, T. Nakayama, and J. Mottl, *J. Quant. Spectrosc. Radiat. Transfer*, **2**, 369 (1962).

(38) A. Maccoll and P. J. Thomas, *Nature (London)*, **170**, 392 (1955); A. Maccoll in "The Chemistry of Alkenes," S. Patai, Ed., Wiley, New York, N. Y., 1964, S. W. Benson and A. N. Bose, *J. Chem. Phys.*, **39**, 3463 (1963).

(39) R. W. Hoffmann, "Dehydrobenzene and Cycloalkynes," Academic Press, New York, N. Y., 1967.

(40) M. P. Cava and M. J. Mitchell, "Cyclobutadiene and Related Compounds," Academic Press, New York, N. Y., 1967.

(41) For calculations of the various benzyne see D. L. Wilhite and J. L. Whitten, *J. Amer. Chem. Soc.*, **93**, 2858 (1971).

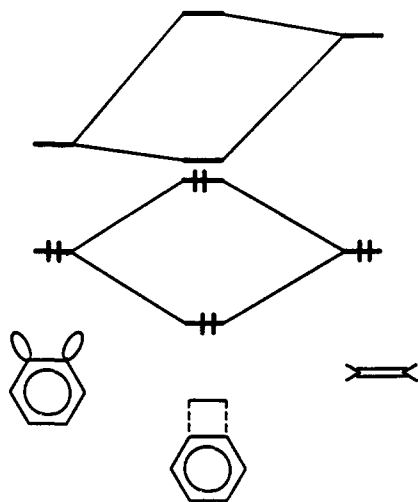
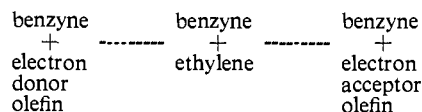

Figure 10. The MO's of the transition state complex for a suprafacial union of benzyne and a good electron donor ethylene.

effectively removes the forbiddenness of the $2_s + 2_s$ pathway is predicted to be more important than in the case of the $2_\pi + 2_\pi$ cycloaddition of two ethylenes because the energy gap separating ψ_2 and ψ_3 of the transition state complex is much smaller in the former than in the latter case. Hence $2_s + 2_s$ concerted addition of benzyne to ethylene will have a lower barrier than $2_s + 2_s$ concerted addition of ethylene to ethylene.

Figure 10 shows the interaction diagram for the cycloaddition of benzyne and a good electron donor olefin which proceeds in a $2_s + 2_s$ manner. The relative energies of the MO's of the cycloaddends have been obtained by reference to already existing calculations and ionization potential and ultraviolet spectroscopy data. The relative energies of the MO's of the transition state complex have been obtained from perturbation calculations. In such reactions configuration interaction is expected to be of much greater importance than in the case of the $2_\pi + 2_\pi$ cycloaddition of a good electron donor olefin and ethylene because the energy gap separating ψ_2 and ψ_3 of the transition state complex is much smaller in the former than in the latter case. Furthermore, configuration interaction is much more important in the case of the cycloaddition of benzyne and a good electron donor olefin than in the case of the cycloaddition of benzyne and ethylene. Accordingly, it is expected that as we increase the electron donating ability of the olefin partner $2_s + 2_s$ concerted addition will become increasingly prominent. The same conclusions are reached in the case of the cycloaddition of benzyne with a good electron accepting olefin. The spectrum of the cycloaddition of benzyne and olefin is shown below.



Configuration interaction becomes extremely important at the ends of the spectrum and, thus, $2_s + 2_s$ stereoselective addition is expected at both ends of the spectrum if competing pathways are uniformly stabilized through the entire spectrum. We shall scrutinize the last point in greater detail.

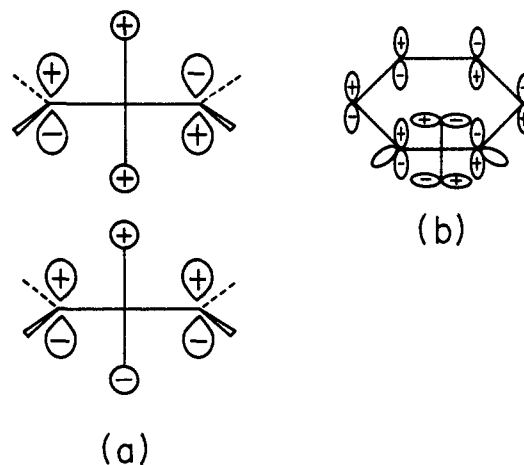

Figure 11. Stabilizing interactions in the $s + a$ transition state of benzyne + ethylene cycloaddition. (a) Interaction of dehydro bond and ethylene. (b) Interaction of benzene ψ_3 and LUMO of ethylene.

We have considered above the electronic facets which give rise to a lowering of the barrier to concerted $2_s + 2_s$ cycloaddition of benzyne and olefin. It has to be borne in mind that the $2_s + 2_a$ mode of union is allowed irrespective of the electronic nature of the olefin partner. In the case of interest, there are extra stability factors present in the transition state of an $2_s + 2_a$ cycloaddition which merit our attention. These factors can be understood by consideration of the orbital interactions at the $2_s + 2_a$ transition state. There are two important interactions: (a) the interactions of the dehydro bond MO's with the MO's of the olefins, and (b) the interactions of the π MO's of the benzene ring with the MO's of the olefin.

These stabilizing interactions are shown in Figure 11. Accordingly, one can expect that $2_s + 2_a$ union of benzyne and olefin might not be a high energy process. We have argued before that in an antarafacial union rotation preferentially occurs within the acceptor partner. Thus, one can expect that $2_s + 2_a$ union will become progressively prominent as one goes from one extreme of the reactivity spectrum involving cycloaddition of benzyne and an electron donating olefin to the other extreme of the spectrum involving addition of benzyne and an electron accepting olefin. Although the relative magnitude of the stabilization of the $2_s + 2_s$ and the $2_s + 2_a$ pathways cannot be deduced on the basis of this simple treatment, it seems reasonable to expect that the overall stereoselectivity of benzyne cycloadditions will vary from $2_s + 2_s$ stereoselective in the case of addition to electron donor olefins to nonstereoselective in the case of addition to electron acceptor olefins due to competing $2_s + 2_s$ and $2_s + 2_a$ pathways. Table III summarizes some of the existing data. It appears that stereoselectivity in the additions of the cis isomer of an olefin increases with decreasing ionization potential and is consistent with our expectation. The trans isomer of some olefins of Table III gives rise to ene products and might not be a convenient model for comparisons. In any event, the expected order is not found in the trans series. Clearly, more stereochemical studies are needed in order to elucidate what might be a very complicated mechanistic problem.

The $4_\pi + 2_\pi$ cycloaddition of benzyne to olefins has

Table III. Stereochemistry of Addition of Olefins to Benzyne

Olefin, RC=CR'	% retention of stereochemistry in cycloadduct
R = Me, R' = OEt (cis)	94 ^b
R = Me, R' = OMe (cis)	88 ^c
R = Me, R' = OAc (cis)	82 ^c
R, R' = Cl (cis)	68 ^d
R = Me, R' = OEt (trans)	79 ^{a,b}
R = Me, R' = OMe (trans)	51 ^{a,c}
R = Me, R' = OAc (trans)	67 ^{a,c}
R, R' = Cl (trans)	81 ^d

^a High component of ene reaction. ^b H. H. Wasserman, A. J. Solodar, and L. S. Keller, *Tetrahedron Lett.*, 5597 (1968). ^c L. Friedman, R. J. Osiewicz, and P. W. Rabideau, *ibid.*, 5735 (1968). ^d Reference 42.

been shown to proceed in the manner predicted by standard orbital symmetry considerations⁴² and does not need any discussion since the situation is quite analogous to the situation of $4_{\pi} + 2_{\pi}$ cycloaddition of a diene and an olefin.

Conclusion

In this work, we have provided arguments in order to show the following.

(a) Correlation diagrams can provide the framework for a detailed analysis of the effect of the electronic properties of the reagents upon the stereoselectivity of the cycloaddition reaction. Correlation diagrams allow for the recognition of the importance of configuration

(42) M. Jones, Jr., and R. H. Levin, *J. Amer. Chem. Soc.*, **91**, 6411 (1969).

interaction in the cases of cycloadditions involving reagents of widely different ionization potential and electron affinity. In this respect, our treatment constitutes an extension of the Woodward-Hoffmann and Longuet-Higgins-Abrahamson treatment.

(b) Non least motion processes can occur whenever configuration interaction is unimportant, while least motion processes can uniformly become allowed whenever configuration interaction becomes important.

(c) Both the stereoselectivity and nonstereoselectivity of different types of cycloadditions can be the result of concerted mechanisms. This implies that the mechanism of many reactions which were previously thought to proceed *via* the intermediacy of diradical or dipolar species either because they were nonstereoselective or because they proceed by a symmetry non-allowed manner has to be reexamined in the light of our findings.

We regard the conclusions reported here as significant and it is important to single out the workers who have expressed ideas related to ours. In this respect, the possibility of concerted $2_s + 2_s$ cycloaddition of singlet oxygen and electron rich olefins has been discussed by Kearns.⁴³ Furthermore, Jackson³⁴ has considered the activation energy of four-center forbidden reactions and implied that enhanced polarity of the transition state can lower the activation energy of such reactions. Finally, the calculations of Raff and Porter³⁵ mentioned before have beautifully illustrated the importance of configuration interaction in reducing the forbiddenness of $2_{\sigma} + 2_{\sigma}$ cycloadditions.

(43) D. R. Kearns, *ibid.*, **91**, 6559 (1969).

Configuration Interaction and Organic Reactivity.

II. Electrocyclic Reactions

Nicolaos D. Epiotis¹

Contribution from the Department of Chemistry, Princeton University, Princeton, New Jersey 08540. Received March 22, 1972

Abstract: The effect of substituents on the stereochemistry of electrocyclic reactions is examined with the aid of perturbation theory at the one-electron level. It is shown that increasing substitution by either electron-releasing or electron-withdrawing groups tends to reverse the stereoselectivity of electrocyclic reactions. The effect of configuration interaction on the stereoselectivity of electrocyclic reactions is examined by an orbital symmetry approach. It is shown that configuration interaction can also give rise to reversal of the stereoselectivity of electrocyclic reactions especially when the system undergoing ring closure or ring opening is asymmetrically substituted by electron-releasing and electron-withdrawing groups.

We have seen that configuration interaction is all important in determining the stereoselectivity of cycloaddition reactions.² We now would like to extend these ideas to the case of electrocyclic ring closures. We shall use two approaches in order to demonstrate that substituents can effect the preference for conrotatory or disrotatory ring closure in conjugated systems. First, we shall use a simple perturbation treatment³ in order to make predictions regarding the stereoselectivity

(1) Address correspondence to the Department of Chemistry, University of Washington, Seattle, Wash. 98105.

(2) N. D. Epiotis, *J. Amer. Chem. Soc.*, **95**, 1191 (1973).

(3) M. J. S. Dewar, "The Molecular Orbital Theory of Organic Chemistry," McGraw-Hill, New York, N. Y., 1969.

of ring closures. Subsequently, we shall use an orbital symmetry approach⁴ and show how configuration interaction can affect the preference for conrotation or disrotation in representative systems.

It is important to realize that ring closures can be viewed as intramolecular cycloadditions. For example, the ring closures of butadiene and hexatriene can be viewed as intramolecular $2 + 2$ and $4 + 2$ cycloadditions. One can derive stereoselection rules for ring closures in a very simple manner by assum-

(4) R. B. Woodward and R. Hoffmann, "The Conservation of Orbital Symmetry," Academic Press, New York, N. Y., 1970; H. C. Longuet-Higgins and E. W. Abrahamson, *J. Amer. Chem. Soc.*, **87**, 2045 (1965).